

A

B

C

D

E

F

1

2

3

4

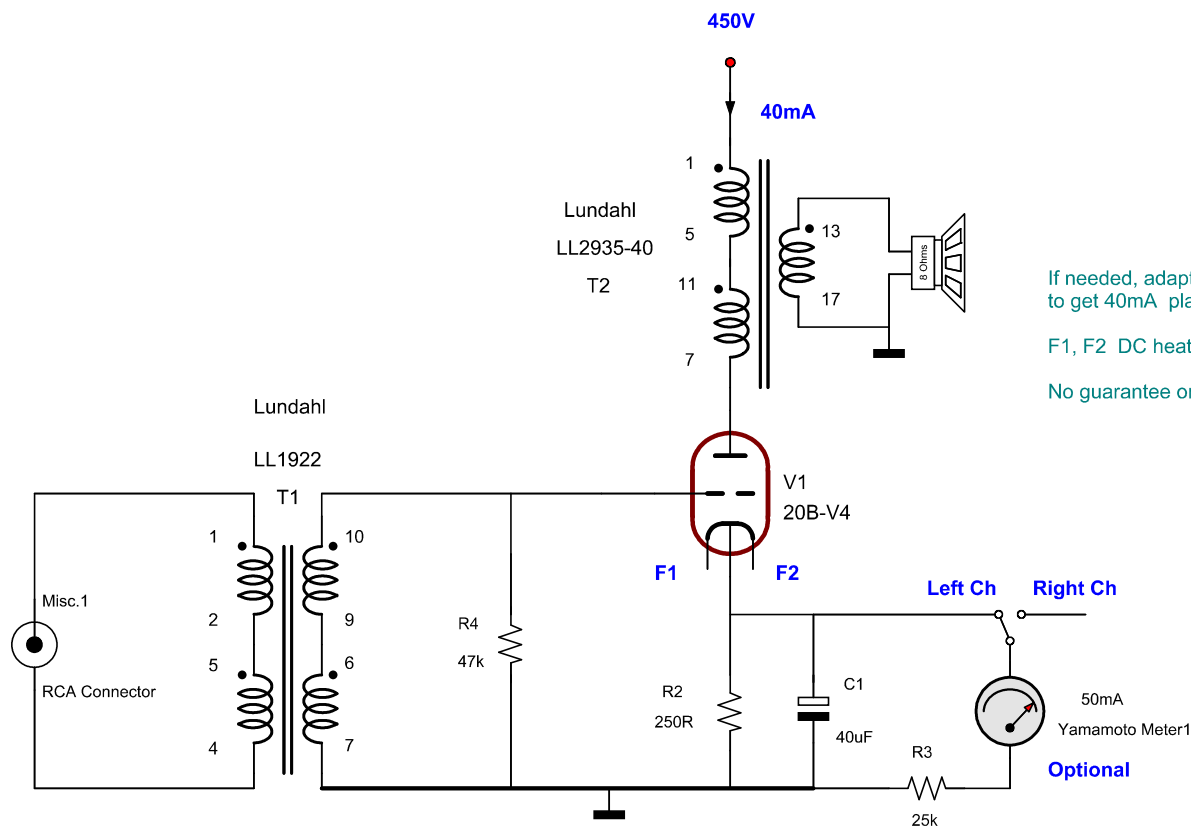

If needed, adapt cathode resistor, to get 40mA plate current.

F1, F2 DC heating recommended

No guarantee on schematic

Attention:

You may publish this page on a private website, as long as you don't change it

Any form of commercial use needs our written permission

JAC Music Company * Horber Steige 25 * Sulz * Germany

Revisions		Date	Name
Date	Name	Drawn	29.12.2014 JW

Dipl. Ing. Jac van de Walle

Name: 20B-V4 One Tube Amplifier OTA-1	
Copyright www.jacmusic.com	Page:
Drawing Nr.:	1 of 2